

Panels

Standard Lugged Panel Insert

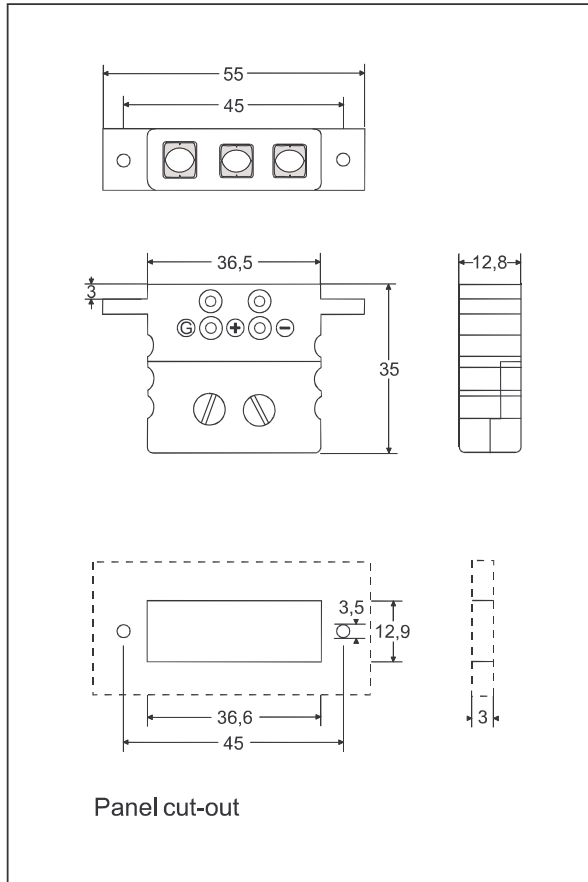

Application: Panel insert for thermocouple and RTD circuits. Third connection for ground or continuous shield or for three wire RTD's. Can be mounted in a single circuit version or in rows in customer panel. Mounting by means of two M 3 screws.

Construction:

- Glass filled thermoplastic body with original thermocouple material pins and springloaded inserts.
- Polarized pins ensure proper connection.
- Central cover screw design for quick wiring.
- Molded barriers prevent short circuit.
- Captive cover screw for easy assembly.

Wire size:

- Accepts wires from 0,2 mm to 2,0 mm.
- Maximum cable diameter 8,0 mm.

Temperature rating:

- 200 Deg. C Max.

Color Code:

- Available in all color code standards. Incl. NFE, BS, JIS, etc.

Accessories :

- All accessories for the miniature connectors can be fitted. See separate specification sheet.

Ordering Code **Plug:** PSITL-xx For last two digits 'xx' see table below
 Example : PSITL-KI = Panel Insert Std. Lugged 3-Pin Type K Green

Calibration Code	E	J	K	N	T	U	R/S	C	B
Compensation material for							Pt13Rh/ Pt	W5Re/ W26Re	Pt6Rh/ Pt30Rh
Material Positive	NiCr	Fe	NiCr	NiCrSi	Cu	Cu	Cu	CPX	Cu
Material Negative	CuNi	CuNi	NiAl	NiSi	CuNi	Cu	Alloy #11	CNX	Cu
IEC Color Code									
Color Body	Violet	Black	Green	Pink	Brown	White	Orange	Red	Grey
Code	EI	JI	KI	NI	TI	UI	RI	C	BI
ANSI Color Code									
Color Body	Violet	Black	Yellow	Orange	Blue	White	Green	Red	Grey
Code	EI	JI	KA	NA	TA	UI	RA	C	BI
DIN Color Code									
Color Body		Blue	Green		Brown		White		Grey
Code		JD	KI		TI		RD		BI

01-08-07

Hamitherm BV – PO Box 433 – 2100 AK Heemstede – The Netherlands.
 Tel. +31 (0)23 547 1283 – Fax +31 (0)23 547 8036 – info@hamitherm.nl - www.hamitherm.nl