

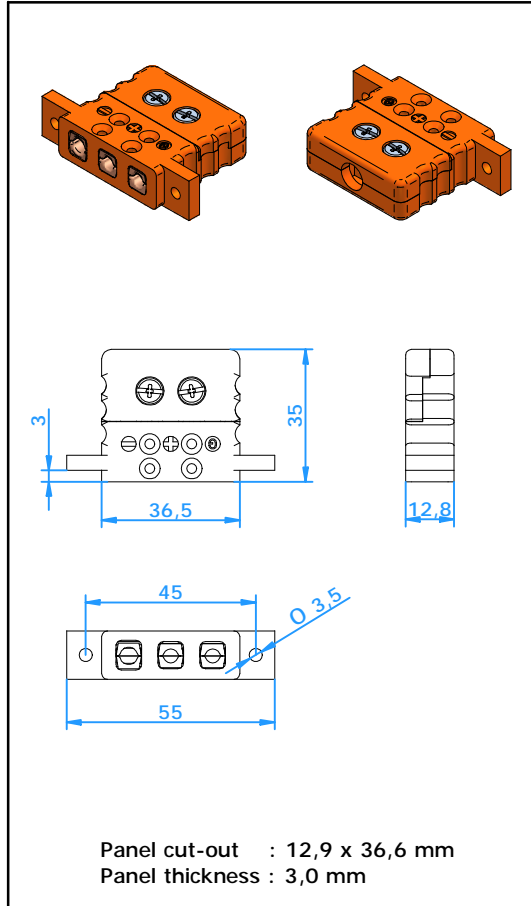

Panels

Standard Panel Insert Three Pin Lugged



Application

Panel insert for thermocouple and RTD circuits.
Third connection for ground or continuous shield or for three wire RTD's. Can be mounted in a single circuit version or in rows in customer panel. Mounting by means of two M3 screws.

Construction

- Glass filled thermoplastic body with original thermocouple material pins and springloaded inserts.
- Polarized pins ensure proper connection.
- Central cover screw design for quick wiring.
- Molded barriers prevent short circuit.
- Captive cover screw for easy assembly.

Wire size

- Accepts wires from 0,2 mm to 2,0 mm.
- Maximum cable diameter 8,0 mm.

Temperature rating

- 200 °C Max.

Color Code

- Available in all color code standards. Incl. NFE, BS, JIS, etc.

Accessories

Most accessories for the standard connectors can be fitted. See separate specification sheet.

Ordering Code : PSITL-xx

For last two digits 'xx' see table below

Calibration Code	E	J	K	N	T	U	R/S	C	B
Compensation material for							Pt13Rh/	W5Re/	Pt6Rh/
Material Positive							Pt	W26Re	Pt30Rh
Material Negative	NiCr	Fe	NiCr	NiCrSi	Cu	Cu	Cu	CPX	Cu
	CuNi	CuNi	NiAl	NiSi	CuNi	Cu	Alloy #11	CNX	Cu
IEC Color Code									
Color Body	Violet	Black	Green	Pink	Brown	White	Orange	Red	Grey
Code	EI	JI	KI	NI	TI	UI	RI	C	BI
ANSI Color Code									
Color Body	Violet	Black	Yellow	Orange	Blue	White	Green	Red	Grey
Code	EI	JI	KA	NA	TA	UI	RA	C	BI
DIN Color Code									
Color Body		Blue	Green		Brown		White		Grey
Code		JD	KI		TI		RD		BI