

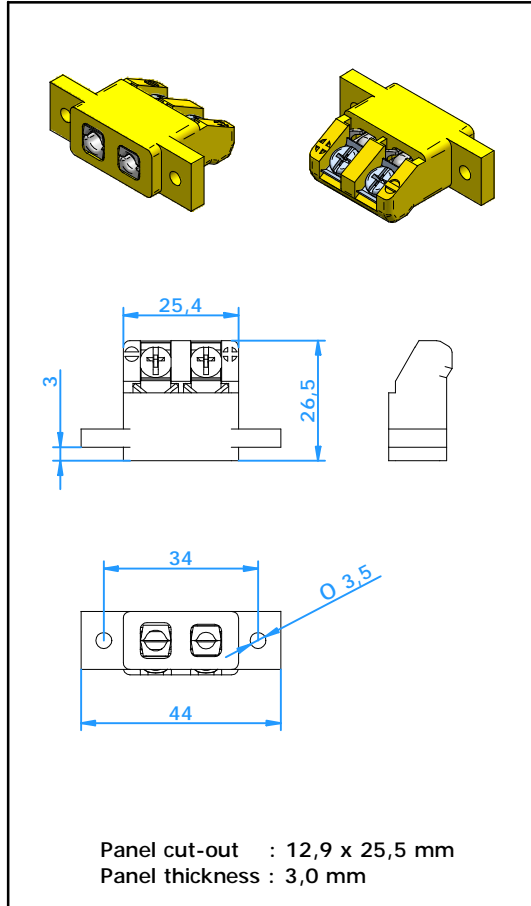

Panels

Standard Panel Insert Lugged



Application

Panel insert for thermocouple and RTD circuits.
Can be mounted in a single circuit version or in rows in customer panels. Mounting by means of two M3 screws.

Construction

- Glass filled thermoplastic body with original thermocouple material pins and springloaded inserts.
- Polarized pins.
- Molded barriers prevent short circuit.
- Polarity indication next to connection screws.

Wire size

- Accepts wires from 0,2 mm to 2,0 mm.

Temperature rating

- 200 °C Max.

Color Code

- Available in all color code standards. Incl. NFE, BS, JIS, etc.

Ordering Code : PSIL-xx

For last two digits 'xx' see table below

Calibration Code	E	J	K	N	T	U	R/S	C	B
Compensation material for Material Positive	NiCr	Fe	NiCr	NiCrSi	Cu	Cu	Pt13Rh/ Pt	W5Re/ W26Re	Pt6Rh/ Pt30Rh
Material Negative	CuNi	CuNi	NiAl	NiSi	CuNi	Cu	Cu Alloy #11	CPX CNX	Cu Cu
IEC Color Code									
Color Body	Violet	Black	Green	Pink	Brown	White	Orange	Red	Grey
Code	EI	JI	KI	NI	TI	UI	RI	C	BI
ANSI Color Code									
Color Body	Violet	Black	Yellow	Orange	Blue	White	Green	Red	Grey
Code	EI	JI	KA	NA	TA	UI	RA	C	BI
DIN Color Code									
Color Body		Blue	Green		Brown		White		Grey
Code		JD	KI		TI		RD		BI