

# Panels

## Standard Panel Insert High Temperature

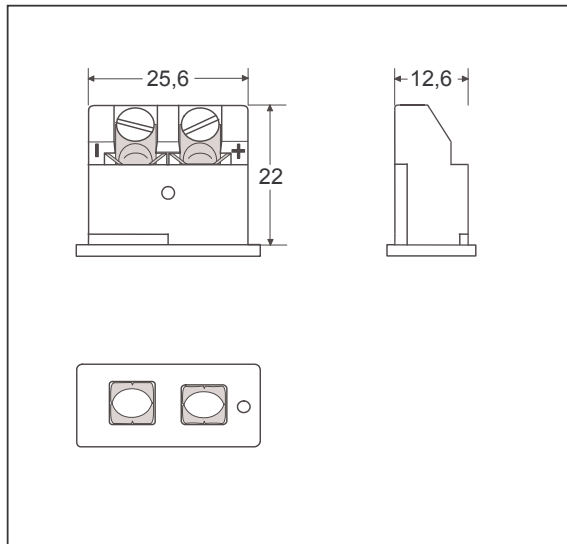

**Application:** Panel insert for thermocouple and RTD circuits.

**Construction:**

- Glass filled thermosetting with original thermocouple material pins and springloaded inserts.
- Polarized pins.
- Molded barriers prevent short circuit.
- Polarity indication next to connection screws.

**Wire size:**

- Accepts wires from 0,2 mm to 2,0 mm.

**Temperature rating:**

- 350 Deg. C Max.

**Color Code:**

- Body color brown. Calibration indication by colored dot.

**Accessories:**

- Can be offered as a complete high temperature panel for six circuits. See separate specification sheet.

**Ordering Code Plug: PSIH-xx**

For last two digits 'xx' see table below

Example : PSIH-KI = Panel Insert Std. High Temp.Type K Green

Calibration Code	<b>E</b>	<b>J</b>	<b>K</b>	<b>N</b>	<b>T</b>	<b>U</b>	<b>R/S</b>	<b>C</b>	<b>B</b>
Compensation material for							Pt13Rh/ Pt	W5Re/ W26Re	Pt6Rh/ Pt30Rh
Material Positive	NiCr	Fe	NiCr	NiCrSi	Cu	Cu	Cu	CPX	Cu
Material Negative	CuNi	CuNi	NiAl	NiSi	CuNi	Cu	Alloy #11	CNX	Cu
<b>IEC Color Code</b>									
Color Dot	Violet	Black	Green	Pink	Brown	White	Orange	Red	Grey
Code	<b>EI</b>	<b>JI</b>	<b>KI</b>	<b>NI</b>	<b>TI</b>	<b>UI</b>	<b>RI</b>	<b>C</b>	<b>BI</b>
<b>ANSI Color Code</b>									
Color Dot	Violet	Black	Yellow	Orange	Blue	White	Green	Red	Grey
Code	<b>EI</b>	<b>JI</b>	<b>KA</b>	<b>NA</b>	<b>TA</b>	<b>UI</b>	<b>RA</b>	<b>C</b>	<b>BI</b>
<b>DIN Color Code</b>									
Color Dot		Blue	Green		Brown		White		Grey
Code		<b>JD</b>	<b>KI</b>		<b>TI</b>		<b>RD</b>		<b>BI</b>

01-08-07

Hamitherm BV – PO Box 433 – 2100 AK Heemstede – The Netherlands.

Tel. +31 (0)23 547 1283 – Fax +31 (0)23 547 8036 – info@hamitherm.nl - www.hamitherm.nl