

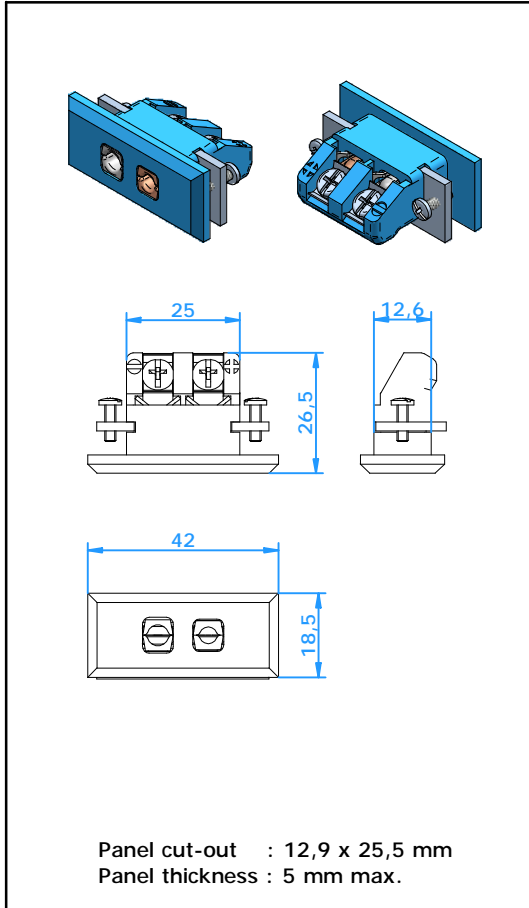

Panels

Standard Panel Insert Flanged Bracket Mounting



Application

Panel insert for thermocouple and RTD circuits. Mounting by means of a stainless steel bracket and two screws.

Construction

- Glass filled thermoplastic body with original thermocouple material pins and springloaded inserts.
- Polarized pins ensure proper connection.
- Molded barriers prevent short circuit.
- Polarity indication on the body
- Rugged one body design.
- Stainless steel screws and bracket for rear mounting (also available with metal spring-clip)

Wire size

- Accepts wires from 0,2 mm to 2,0 mm.

Temperature Rating

- 200 °C Max.

Color Code:

- Available in all color code standards, incl. NFE, BS, JIS, etc.

Ordering Code : PSIFB-xx
PSIF-xx

For last two digits 'xx' see table below
spring clip mounting

Calibration Code	E	J	K	N	T	U	R/S	C	B
Compensation material for							Pt13Rh/	W5Re/	Pt6Rh/
Material Positive							Pt	W26Re	Pt30Rh
Material Negative	NiCr	Fe	NiCr	NiCrSi	Cu	Cu	Cu	CPX	Cu
	CuNi	CuNi	NiAl	NiSi	CuNi	Cu	Alloy #11	CNX	Cu
IEC Color Code									
Color Body	Violet	Black	Green	Pink	Brown	White	Orange	Red	Grey
Code	EI	JI	KI	NI	TI	UI	RI	C	BI
ANSI Color Code									
Color Body	Violet	Black	Yellow	Orange	Blue	White	Green	Red	Grey
Code	EI	JI	KA	NA	TA	UI	RA	C	BI
DIN Color Code									
Color Body		Blue	Green		Brown		White		Grey
Code		JD	KI		TI		RD		BI