

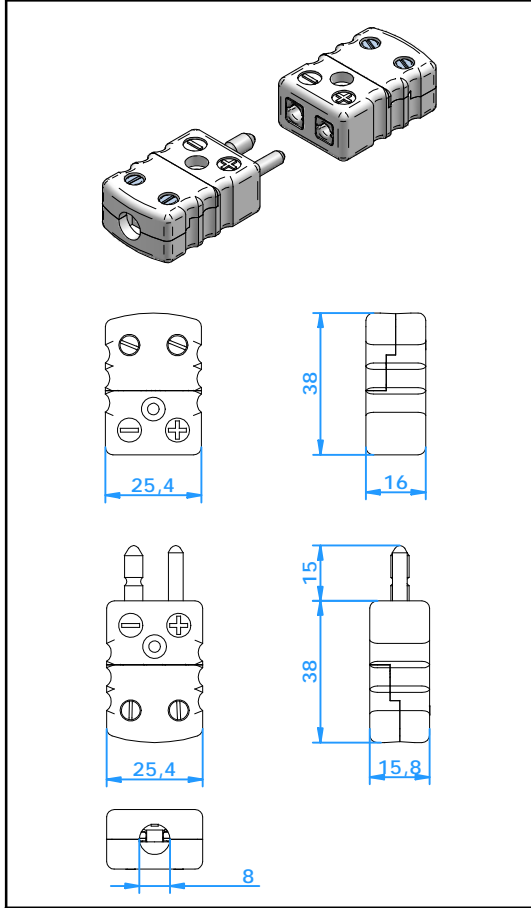

Connectors

Standard Connector Ceramic



Application

Connector for thermocouple and RTD circuits. Solid pin design ensures good contact even in demanding applications. Hollow pin design offers a good quality product at competitive pricing for less frequently used connectors.

Construction

- Ceramic body with original thermocouple material pins and springloaded inserts.
- Polarized pins ensure proper connection.
- Oversize terminal screw head for easy wiring
- One body design.
- High purity alumina body material.

Wire size

- Accepts wires from 0,2 mm to 2,0 mm.
- Maximum cable diameter 8,0 mm.

Temperature rating

- 650 °C Max.

Color Code

- Body color white with color dot.

Accessories

- See separate specification sheet.

Ordering Code Plug Solid Pin : CSPC-x x = Calibration Code (See table below)
 Plug Hollow Pin: CSPCL-x
 Jack : CSJC-x

Calibration Code	E	J	K	N	T	U	R/S	C	B
Compensation material for Material Positive	NiCr	Fe	NiCr	NiCrSi	Cu	Cu ¹⁾	Pt13Rh/ Pt	W5Re/ W26Re	Pt6Rh/ Pt30Rh
Material Negative	CuNi	CuNi	NiAl	NiSi	CuNi	Cu ¹⁾	Cu Alloy #11	CPX CNX	Cu ¹⁾ Cu ¹⁾
IEC Color Code	Violet	Black	Green	Pink	Brown	White	Orange	Red	Grey
Color Dot Code	EI	JJ	KI	NI	TI	UI	RI	C ²⁾	BI
ANSI Color Code	Violet	Black	Yellow	Orange	Blue	White	Green	Red	Grey
Color Dot Code	EI	JJ	KA	NA	TA	UI	RA	C ²⁾	BI
DIN Color Code		Blue	Green		Brown		White		Grey
Color Dot Code		JD	KI		TI		RD		BI

Note ¹⁾ Copper pins are also available with a hard nickel plating, please add "NP" after the calibration code
²⁾ Type C connector plug is only available in a hollow pin version